

## Flat Top 2000

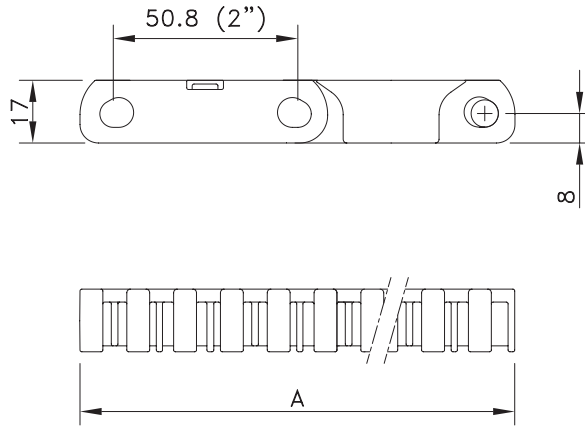
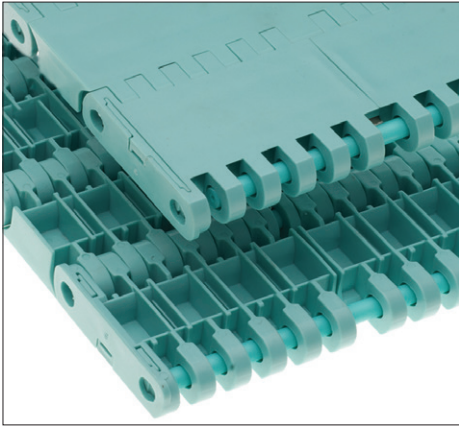

Assembly	Belt Type	Code Number*	Temperature range °C		Working Load (max.) N/m (21°C)	Weight kg/m <sup>2</sup>	Backflex Radius (min.) mm
			Dry	Wet			
<b>XP-Polypropylene with Polypropylene Pins</b>							
Standard	XP 2000 FT	838.30.xx	4 to 104	4 to 104	29500	8.20	45

\* In code numbers xx corresponds with the belt width (A), starting with 10 for 3", 11 for 6" and so on in steps of 3". See also page 223.

## Flush Grid 2000

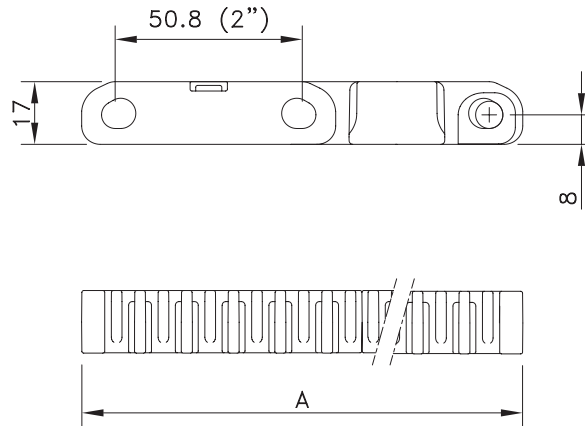
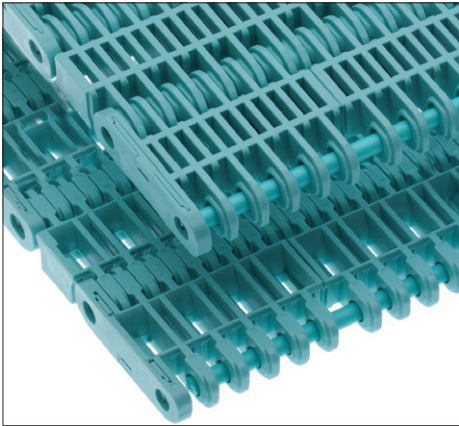

Assembly	Belt Type	Code Number*	Temperature range °C		Working Load (max.) N/m (21°C)	Weight kg/m <sup>2</sup>	Backflex Radius (min.) mm
			Dry	Wet			
<b>XP-Polypropylene with Polypropylene Pins</b>							
Standard	XP2000FG	838.40.xx	4 to 104	4 to 104	29500	7.55	35

\* In code numbers xx corresponds with the belt width (A), starting with 10 for 3", 11 for 6" and so on in steps of 3". See also page 223.